



SHIP PARTICULARS

12K-160

Name	Built	IMO-No.	Flag
Mauritius Pride II	2007	9359935	Cyprus

GENERAL INFORMATION

Type	Box-Hold MPP Tweendecker
Class	DNV GL

TONNAGE

DWT	12,652 MT
GT	9,938
NT	4,265

MAIN DATA

LOA	139.96 m
Beam	21.50 m
Summer Draft	8.40 m
Max Speed	abt. 13.5 knots

HOLDS/HATCHES

Number	3 Holds / 3 Hatches
Hatch No. 1	20.30 x 7.20 m (F) 11.70 m (A)
Hatch No. 2	39.20 x 18.40 m
Hatch No. 3	25.90 x 18.40 m

CARGO CAPACITY

with Tweendeck	16,113 cbm Bale
----------------	-----------------

FLOOR SPACE

Under Deck	2,784 m ²
On Deck	1,436 m ²
Total	4,220 m ²

MAX. PERMISSABLE LOAD

Tanktop	18.0 mt/ m ²
Tweendeck	3.0 mt/m ²
Hatchcovers	3.0 mt/m ²

CONTAINERS CAPACITY

Total	696 TEU
Reefer Plugs	138

CARGO HANDLING GEAR

Cranes	2 x 80 mt + 1 x 45 mt
Combined Lift Capacity	160 mt

SPECIAL EQUIPMENT/FEATURE

IMO fitted	Yes
Lakes Fitted	
CO2 Fitted	Yes
A60 Bulk Head	
Grain Fitted	
Bowthruster	Yes

All details including speed are given in good faith and can vary on the individual vessels. They are to be considered „about“, are given without guarantee and must not be used as basis for charterparties or contracts without Intermarine's explicit written authority. For further information, please contact info@intermarine.com // **Last Revised: June 2024**

BACK

SIDE

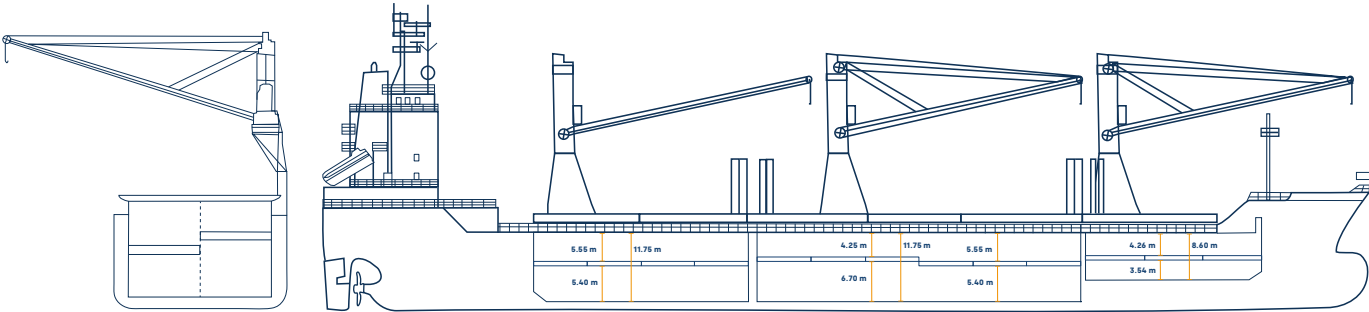

MAINDECK

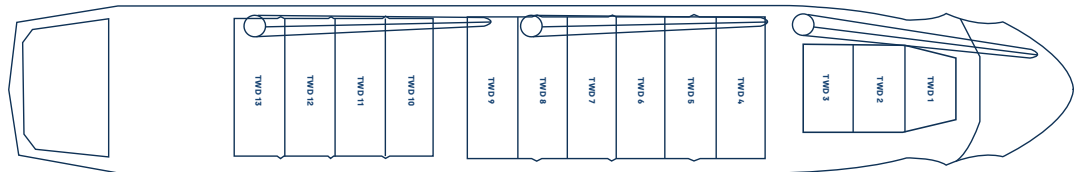

TANKTOP

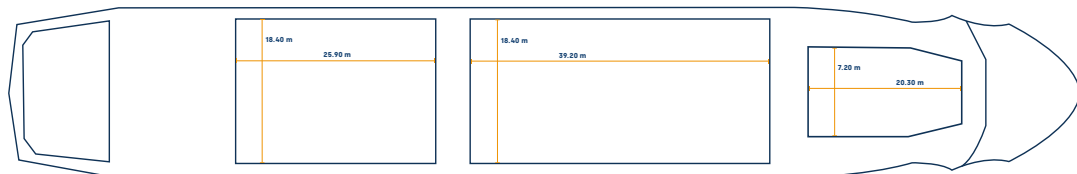

All details including speed are given in good faith and can vary on the individual vessels. They are to be considered „about“, are given without guarantee and must not be used as basis for charterparties or contracts without Intermarine’s explicit written authority. For further information, please contact info@intermarine.com // **Last Revised: June 2024**